

**SASAMAT VOLUNTEER FIRE DEPARTMENT (SVFD)
BOARD OF TRUSTEES MEETING**

REGULAR MEETING

**Thursday, September 5, 2024
7:00 P.M.
In-person at the Anmore Community Hub**

A G E N D A

1. ADOPTION OF THE AGENDA

1.1 September 5, 2024 Regular Meeting Agenda

That the SVFD Board of Trustees adopt the agenda for its regular meeting scheduled for September 5, 2024 as circulated.

2. ADOPTION OF THE MINUTES

2.1. March 14, 2024 Regular Meeting Minutes

That the SVFD Board of Trustees adopt the minutes for its regular meeting held March 14, 2024 as circulated.

3. REPORTS FROM COMMITTEE OR STAFF

3.1 SVFD Service Review

That the Sasamat Volunteer Fire Department (SVFD) Board of Trustees receive for information the verbal update regarding a service review.

3.2 Loan Authorization Bylaw and budget planning for SVFD capital facilities

That the Sasamat Volunteer Fire Department (SVFD) Board of Trustees receive for information the report titled "Borrowing Process and Budget Impact for the Construction of New Fire Halls."

3.3 2025 Draft Budget – Sasamat Fire Protection Service

That the Sasamat Volunteer Fire Department (SVFD) Board of Trustees endorse the 2025 - 2029 Financial Plan for the Sasamat Fire Protection Service as presented in the report "2025 - 2029 Financial Plan – Sasamat Fire Protection Service" dated September 3, 2024 and forward it to the Finance Committee on October 9, 2024 for consideration.

3.4 2024 SVFD Quarterly Work Plan Update

That the SVFD Board of Trustees receive for information the update to the Quarterly Work Plan as presented in the report “2024 SVFD Quarterly Work Plan Update” dated September 3, 2024.

3.5 Fire Chief’s Report

That the Sasamat Volunteer Fire Department (SVFD) receive for information the report “SVFD Fire Chief’s Report”.

4. INFORMATION ITEMS

None

5. OTHER BUSINESS

6. ADJOURNMENT/CONCLUSION

That the Sasamat Volunteer Fire Department (SVFD) Board of Trustees adjourn/conclude its regular meeting of September 5, 2024.

Membership:

Penner, Darrell (C) - MV Board
Clark, Carolina - Village of Belcarra
McEwen, John - Village of Anmore
Ross, Jamie - Village of Belcarra
Trowbridge, Kim - Village of Anmore
Weverink, Paul - Village of Anmore
Wilder, Liisa - Village of Belcarra

**SASAMAT VOLUNTEER FIRE DEPARTMENT (SVFD)
BOARD OF TRUSTEES MEETING**

Minutes of the Regular Meeting of the Sasamat Volunteer Fire Department (SVFD) Board of Trustees held at 7:00 p.m. on Thursday, March 14, 2024 in person.

MEMBERS PRESENT:

Chair, Councillor Darrell Penner, Port Coquitlam
Councillor Carolina Clark, Belcarra
Mayor John McEwen, Anmore
Mayor Jamie Ross, Belcarra
Councillor Paul Weverink, Anmore
Councillor Liisa Wilder, Belcarra
Councillor Kim Trowbridge, Anmore

STAFF PRESENT:

Jay Sharpe, Fire Chief, Sasamat Volunteer Fire Department, Metro Vancouver
Bill Duvall, Director, Corporate Safety, Security and Emergency Management, Metro Vancouver
Amie Hadley, Office Supervisor, Corporate Safety, Security and Emergency Management, Metro Vancouver

1. ADOPTION OF THE AGENDA

1.1 March 14, 2024 Regular Meeting Agenda

It was MOVED and SECONDED

That the Sasamat Volunteer Fire Department (SVFD) Board of Trustees adopt the agenda for its regular meeting scheduled for March 14, 2024 as circulated.

CARRIED

2. ADOPTION OF THE MINUTES

2.1 October 26, 2023 Special Meeting Minutes

It was MOVED and SECONDED

That the Sasamat Volunteer Fire Department (SVFD) Board of Trustees adopt the minutes for its special meeting held October 26, 2023 as circulated.

CARRIED

3. INVITED PRESENTATIONS

None

4. REPORTS FROM COMMITTEE OR STAFF

4.1 2023 Financial Actuals – Sasamat Fire Protection Service

Bill Duvall reviewed expenditures with Trustees.

MV Finance did not make adjustment to budget in 2023 to remove line for a full time fire chief. As a result, the villages requisitions were reduced to adjust for this amount.

Fleet costs were reviewed and the table on p.3 of report was highlighted detailing the change orders for the new fire engine.

It was MOVED and SECONDED

That the SVFD Board of Trustees receive for information the status update of the 2023 financials as presented in the report dated March 4, 2024 titled “2023 Financial Actuals – Sasamat Fire Protection Service”.

CARRIED

4.2 2024 SVFD Quarterly Work Plan Update

Update included a report out of 2023 quarter 4 items as well as the 2024 Work Plan update.

Audiometric testing not completed in 2023 and will be scheduled in quarter 1 of 2024.

New items in 2024 included working on tender 2 replacement.

Clarification was requested by Trustees on item from 2024 2nd quarter, the transfer of data is from previous software to new system FireQ.

There was discussion regarding BC Hydro, these services are coming at a significant cost. Trustees would like to look into an increase in contribution. Discussion ensued on a fee for service model and other available options. MV staff to look into historical rates and do an analysis prior to agreeing on a number.

Live fire moved from December 2023 to 1st quarter of 2024, but unlikely to happen until later in the year due to available time slots and site issues.

It was MOVED and SECONDED

That the SVFD Board of Trustees instruct Metro Vancouver staff administering the SVFD Service to review the annual contribution levels from both BC Hydro and Metro Vancouver Parks and request both entities to provide an increased annual contribution at a rate agreeable to the SVFD Fire Chief and the Metro Vancouver staff administering the SVFD Service.

CARRIED

It was MOVED and SECONDED

That the SVFD Board of Trustees endorse the Work Plan as presented in the report dated March 4, 2024 titled “2024 SVFD Quarterly Work Plan Update”.

CARRIED

4.3 Fire Chief's Report

Manpower – Currently 39 responders.

Equipment – Engine 3 now in service. Continue to work on specifications for tender 2 replacement. Looking for direction from Trustees on Engine 3 – options to sell or donate.

Halls and Grounds – Main truck bay overhead heater at Anmore has been replaced. Tarmac at Anmore Hall in front of Rescue 5 bay needs to be repaired.

Training – 4 new recruits.

Have started to do school tours again for purpose of public education.

Reports and Information:

Noticeable improvement in radio performance following antenna replacement at Belcarra Hall.

Discussion followed regarding Engine 3 including selling to private owner or posting on government auction website which opens up to international market.

It was MOVED and SECONDED

That the Sasamat Volunteer Fire Department (SVFD) Board of Trustees instruct Metro Vancouver staff administering the SVFD Service to sell the existing Engine 3 through direct sale, auction, or other means reasonably determined by staff.

CARRIED

It was MOVED and SECONDED

That the Sasamat Volunteer Fire Department (SVFD) Board of Trustees receive for information the report dated March 4, 2024, titled "SVFD Fire Chief's Report".

CARRIED

5. INFORMATION ITEMS

5.1 2023 Call-Out Statistics

Jay Sharpe provided some context to call-out statistics; sometimes multiple medical calls can be attributed to a single resident.

Power lines down can be called in as fire calls.

Call volume has increased resulting in the highest year ever.

It was MOVED and SECONDED

That the Sasamat Volunteer Fire Department (SVFD) Board of Trustees receive for information the report dated March 4, 2024, titled "2023 Call-Out Statistics".

CARRIED

6. OTHER BUSINESS

Tour of Bowen Island fire hall proposed for April 19th. Trustees to confirm availability and MV staff to send out invite.

SVFD branded jackets potentially ready within the next two weeks.

7. RESOLUTION TO CLOSE MEETING

It was MOVED and SECONDED

That the Sasamat Volunteer Fire Department (SVFD) Board of Trustees close its regular meeting scheduled for March 14, 2024 pursuant to the Community Charter provisions, Section 90 (1)(e) and 90(1)(k) as follows:

“90 (1) A part of the meeting may be closed to the public if the subject matter being considered relates to or is one or more of the following:

e. the acquisition, disposition or expropriation of land or improvements, if the council considers that disclosure could reasonably be expected to harm the interests of the municipality;

k. negotiations and related discussions respecting the proposed provision of a municipal service that are at their preliminary stages and that, in the view of the council, could reasonably be expected to harm the interests of the municipality if they were held in public;

CARRIED

8. ADJOURNMENT/CONCLUSION

It was MOVED and SECONDED

That the Sasamat Volunteer Fire Department (SVFD) Board of Trustees adjourn/conclude its regular meeting of March 14, 2024.

CARRIED

(Time: 8:30 p.m.)

To: Sasamat Volunteer Fire Department Board of Trustees

From: Linda Sabatini, Director Financial Operations

Date: August 27, 2024 Meeting Date: September 5, 2024

Subject: **Borrowing Process and Budget Impact for the Construction of New Fire Halls**

RECOMMENDATION

That the SVFD Board of Trustees receive for information the Report dated August 27, 2024 outlining the process for borrowing through MVRD from the Municipal Finance Authority of British Columbia (MFA) and the related budget impact to service the debt.

EXECUTIVE SUMMARY

The two existing Sasamat Fire Protection Service's fire halls are essential infrastructure and are in need of replacement. At the October 26, 2023 Sasamat Volunteer Fire Department (SVFD) Board of Trustees meeting, the Trustees endorsed the Facilities Replacement Report and approved the release of up to \$500,000 from the Sasamat Fire Protection Service's Capital Facility Reserve Fund to fund preliminary design for the replacement of the two fire halls. In addition to the cost of the preliminary design, the construction costs for the facilities are currently projected in the range of \$14M to \$20M, far exceeding the estimated available balance in the Capital Facility Reserve of \$660,000 at the end of 2024. This report provides information of the borrowing process to finance the construction costs for the proposed new fire halls through MVRD from the Municipal Finance Authority of British Columbia (MFA) and the related budget impact for consideration.

PURPOSE

To provide for information, the borrowing process to finance the construction of the proposed new fire halls and the related budget impact for such financing.

BACKGROUND

The SVFD is a MVRD function, established by Supplementary Letters Patent dated January 10, 1980 and amended by Supplementary Letters Patent dated March 10, 1989, to provide fire protection services to the Villages of Anmore and Belcarra. The Board of Trustees are exploring the replacement of the two existing fire halls through debt financing from the MFA.

BORROWING PROCESS

Regional districts and municipalities in the British Columbia are required to finance all long-term borrowing through the MFA. The Local Government Act (LGA) and the Community Charter require local governments to follow a robust approval process that can take up to six to eight months, before such financing can be obtained. Generally, the process requires several steps including:

- the adoption of a loan authorization bylaw;
- the adoption of a temporary borrowing bylaw (optional);
- the adoption a security issuing bylaw;
- approvals from the provincial inspector;
- elector approval; and
- review by the MFA.

In the case of SVFD, as a MVRD function, MVRD would incur the debt obligation and the debt servicing costs related to the obligation would be funded from the SVFD annual tax levy.

The process and some of the applicable sections of the LGA and Community Charter are briefly outlined in the following sections. A flowchart of the loan authorization bylaw, temporary borrowing bylaw, and security issuing bylaw procedures are included in Attachment 1.

Loan Authorization Bylaw

The first step in the MVRD borrowing process, is for MVRD to adopt a loan authorization bylaw pursuant to section 179 of the Community Charter and sections 406 and 407 of the LGA (Attachment 1, Figure 1). The loan authorization is approval for a block of borrowing, in advance of any actual borrowing. The loan authorization bylaw must set out:

- (a) the total amount proposed to be borrowed under the bylaw;
- (b) the purposes for which the debt is to be incurred;
- (c) the amount allocated by the bylaw to each of the purposes for which the debt is to be incurred; and
- (d) the maximum term for which the debt may be issued. The maximum term is the lesser of
 - (i) 30 years, and
 - (ii) the reasonable life expectancy of the capital asset for which the debt is contracted

The adoption of the bylaw will involve the following steps:

- 1) Receive three readings of the bylaw by the MVRD Board;
- 2) Forward the bylaw to the Provincial Inspector of Municipalities for approval. (The Inspector of Municipalities is a statutory position with the provincial Ministry of Municipal Affairs.);
- 3) Obtain approval of the participating area;
- 4) Submit to MVRD Board for final adoption;
- 5) Await a one-month quashing period in which the bylaw could be challenged in court;
- 6) Obtain the MVRD's Corporate Officer's Certificate; and
- 7) Receive the Certificate of Approval by the Inspector of Municipalities.

Subject to certain exceptions, Section 407 of the LGA requires that a loan authorization bylaw receive participating area approval. There are three main methods to obtain participating area approval:

- The first is by way of the alternate approval process where MVRD will advertise publicly the proposed borrowing for SVFD. Ten percent or more of the participating electorate (i.e. residents of Anmore and Belcarra) must respond negatively for the bylaw approval to fail (unless assent of the electors is thereafter obtained).
- The second option would be to seek resolution through referendum (elector assent), a much slower and costly process.
- The final option is for the council of each participating area to give participating area approval by consenting on behalf of the electors to adoption of the proposed bylaw.

Temporary Borrowing Bylaw

As an optional next step, upon final adoption of the long-term borrowing bylaw, MVRD would seek approval of a temporary borrowing bylaw for the SVFD service to provide flexibility for cash management in periods of construction. The MFA has two bond issues per year, one in the spring and one in the fall, which provides the opportunity for long-term borrowing. In intervening months, the MFA provides temporary financing to municipalities and regional districts at variable interest rates over terms of not more than five years. During periods of construction, temporary borrowing allows for flexible cash management options to pay interest only until the asset is completed and in service and final costs for long-term borrowing can be determined.

The total amount specified in a temporary borrowing bylaw must be equal to or less than the amount approved in the adopted loan authorization bylaw, minus any temporary or other borrowing completed under the loan authorization bylaw to date. The adoption of the bylaw (Attachment 1, Figure 2) involves three readings and adoption by the MVRD Board. Final approval is from MFA where they would receive and approve the application and issue loan documentations.

Security Issuing Bylaw

The final step in long-term borrowing is done when it is time to actually borrow long-term and receive funds from MFA. This step involves the adoption of a security issuing bylaw (Attachment 1, Figure 3) to authorize the borrowing from MFA to participate in the spring or fall borrowing opportunity. The amount of borrowing requested in the security issuing bylaw cannot exceed the amount approved in the adopted loan authorization bylaw, minus any temporary or other borrowing completed under the loan authorization bylaw to date.

The adoption of the security issuing bylaw involves the following steps:

- 1) Receive three readings and adoption of the bylaw by the MVRD Board;
- 2) Forward the bylaw to the Provincial Inspector of Municipalities for approval;
- 3) Await a 10-day quashing period in which the bylaw could be challenged in court;
- 4) Obtain the MVRD's Corporate Officer's Certificate;
- 5) Receive the Certificate of Approval by the Inspector of Municipalities; and
- 6) Forward to MFA for approval and issuance of loan documentation

FUNDING THE DEBT OBLIGATION

In the case of SVFD, as a MVRD function, MVRD would incur the debt obligation and any debt servicing costs related to the obligation would be funded from the SVFD annual tax levy. By March 31 of each year, the MVRD must adopt a five-year financial plan that sets out the proposed expenditures and funding sources, including tax revenues, for each service. Pursuant to section 385(1) and 387(1) of the LGA, a regional district must provide a tax requisition by April 10 each year to the provincial Surveyor of Taxes and to each municipality that states the amount required from the municipality for the service during the year. The amount requisitioned is a debt due by the municipality to the regional district and must be paid to the regional district by August 1 of the same year. With respect to the Sasamat Fire Protection Service, the Villages of Anmore and Belcarra will each collect the amount requisitioned through property taxes.

HOUSEHOLD TAX IMPACT (HHI)

At the October 26, 2023 meeting, the projected project budget with 30% contingency per fire hall of \$7.4M was presented to the Board of Trustees. Based on the projection and the potential upward amount for consideration, Financial Planning Division has assessed the Household Tax Impact (HHI) as a result of borrowing two potential loan amounts (\$14M and \$20M) under two potential loan terms (20-year and 30-year terms). Based on additional assumptions outlined in Attachment 2, the estimated annual debt service costs range from \$830,000 to \$1,500,000 and the projected household impact range from \$510 to \$925 for Anmore and \$905 to \$1,655 for Belcarra. When the preliminary design findings become available, Finance will leverage these findings to model household tax impact and debt service costs for each fire hall more precisely.

ALTERNATIVES

This is an information report; no alternatives have been presented.

FINANCIAL IMPLICATIONS

The construction costs for replacing the two fire halls are currently projected in the range of \$14M to \$20M. Based on the debt scenarios to borrow two potential loan amounts (\$14M and \$20M), the estimated annual debt service costs range from \$830,000 to \$1,500,000 and the projected incremental household impact range from \$510 to \$925 for Anmore and \$905 to \$1,655 for Belcarra.

CONCLUSION

This report provides information on the process for borrowing through MVRD from the Municipal Finance Authority of British Columbia (MFA) and the related budget impact to service the debt. Since the funding and financing of the proposed replacement of the fire halls as well as the estimated construction costs for each fire hall are still under review, operating funds to service the debt are not set aside in the 2025 budget to address these matters.

ATTACHMENTS

1. Municipal Finance Authority Flowcharts, outlining the process for loan authorization, temporary borrowing, and security issuing bylaws pursuant to the *Local Government Act* and *Community Charter*.
2. Scenario modelling of debt borrowing and related budget impact

Figure 1

Loan Authorization Bylaw Procedures

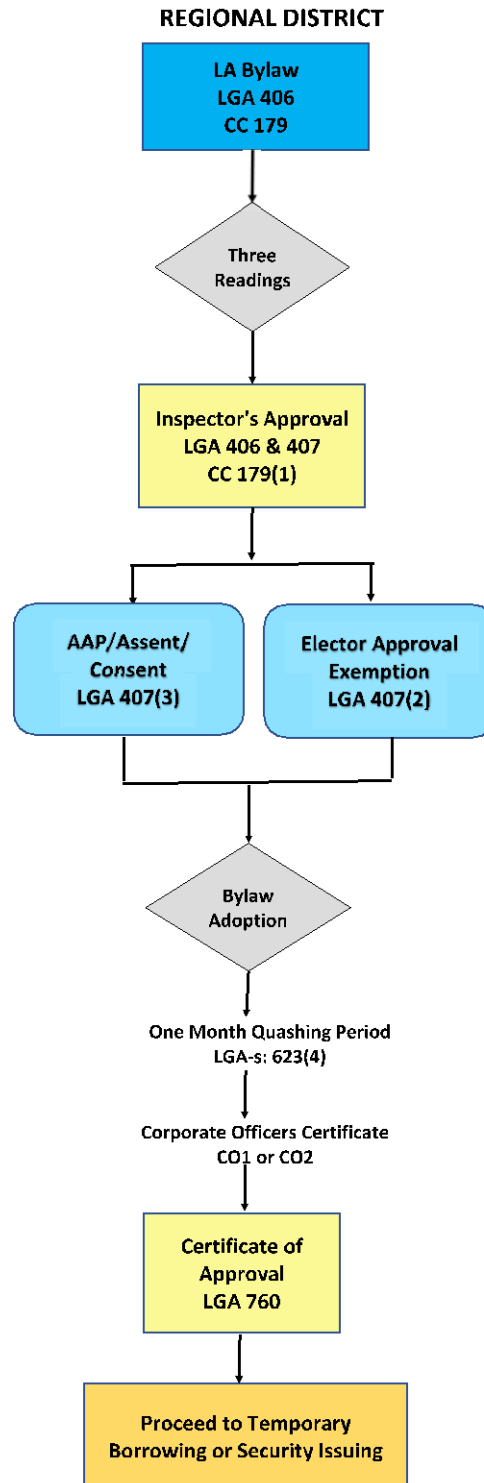
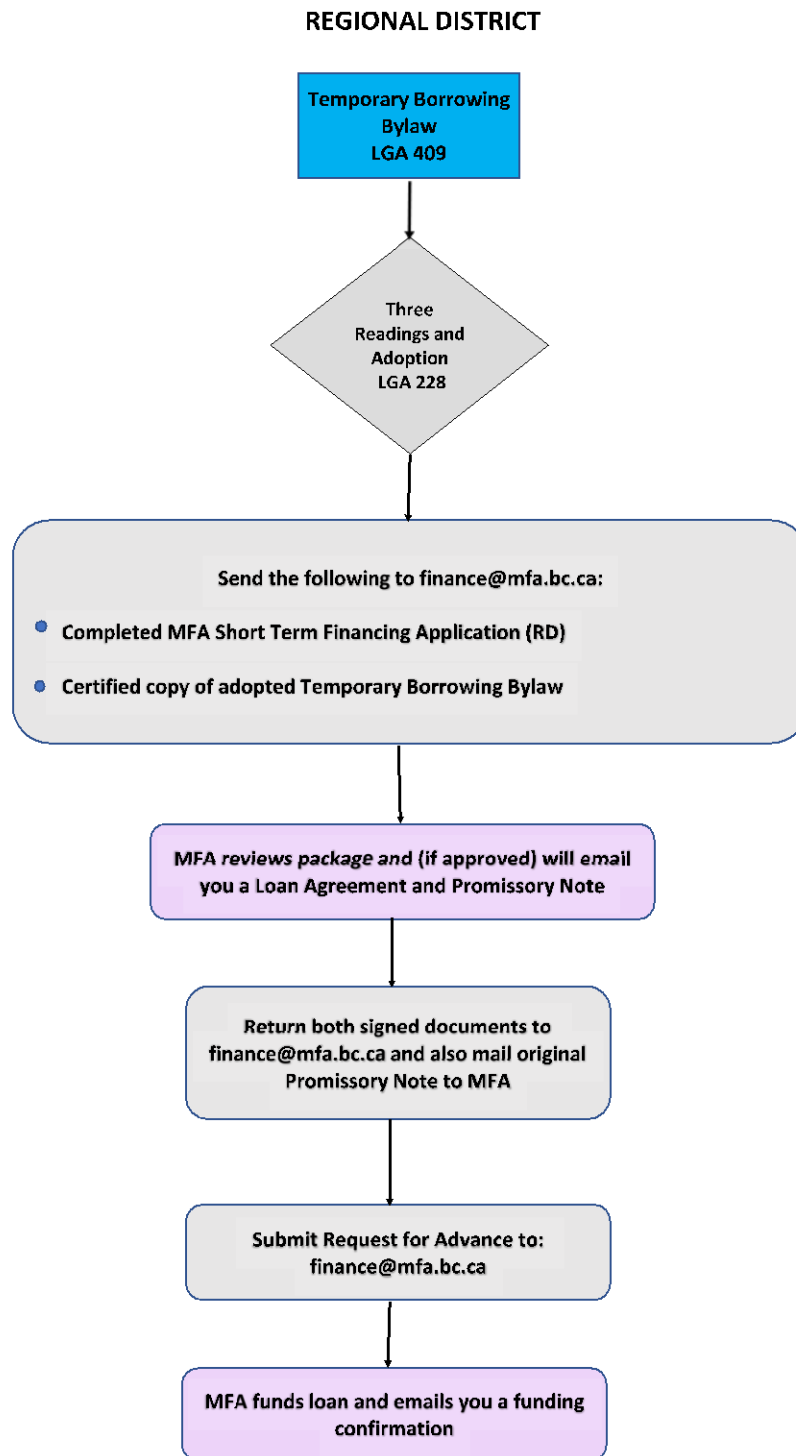

Figure 2

Temporary Borrowing Bylaw Procedures



Source: MFA Website

Figure 3

Security Issuing Bylaw Procedures

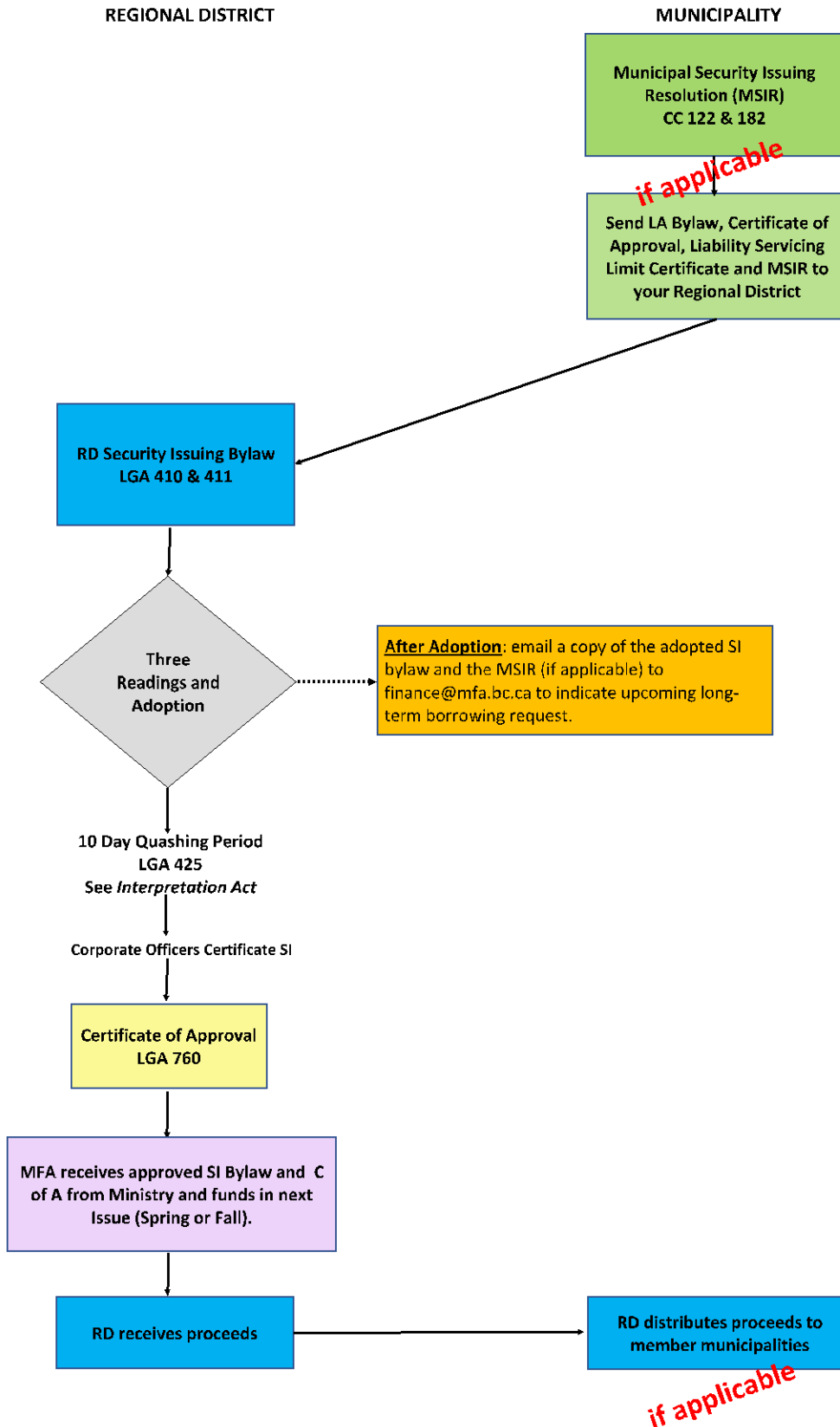

Scenario modelling of debt borrowing and related budget impact

The chart below presents the household tax impact and estimated annual debt servicing costs for the Villages of Anmore and Belcarra.

Key assumptions for the model include:

- Long-term borrowing rate: 4%
- Construction Costs Scenarios: \$14M Scenario, and \$20M Scenario
- Loan Term Scenarios: 20-year and 30-year terms

Scenario		Municipality	Average Incremental HHI Over Life of the Loan	Estimated Annual Debt Service Cost	% Share of Debt Service Costs
20 Year Loan	14M	Anmore	\$ 650	\$ 525,000	50%
		Belcarra	\$ 1,155	\$ 525,000	50%
		Total		\$ 1,050,000	
	20M	Anmore	\$ 925	\$ 750,000	50%
		Belcarra	\$ 1,655	\$ 750,000	50%
		Total		\$ 1,500,000	
30 Year Loan	14M	Anmore	\$ 510	\$ 415,000	50%
		Belcarra	\$ 905	\$ 415,000	50%
		Total		\$ 830,000	
	20M	Anmore	\$ 730	\$ 590,000	50%
		Belcarra	\$ 1,295	\$ 590,000	50%
		Total		\$ 1,180,000	

Legend:

Low End
High End

To: Sasamat Volunteer Fire Department Board of Trustees

From: Brant Arnold-Smith, Program Manager, Protective Services and Emergency Management

Date: September 3, 2024 Meeting Date: September 5, 2024

Subject: **2025 Draft Budget – Sasamat Fire Protection Service**

RECOMMENDATION

That the Sasamat Volunteer Fire Department (SVFD) Board of Trustees endorse the 2025 - 2029 Financial Plan for the Sasamat Fire Protection Service as presented in the report “2025 - 2029 Financial Plan – Sasamat Fire Protection Service” dated September 3, 2024 and forward it to the October 9, 2024 Metro Vancouver Finance Committee for consideration, and then to the November 1, 2024 Metro Vancouver Board for approval.

EXECUTIVE SUMMARY

This report focuses on the Sasamat Fire Protection Service (“Service”) and presents the 2025 provisional annual budget and the updated five-year plan for the years 2025 to 2029 for SVFD Board of Trustees and Metro Vancouver Board of Directors consideration. If the MVRD Board endorses the 2025 - 2029 Financial Plan for Sasamat Fire Protection Service, as presented under Alternative 1, in 2025, the Service requisition in 2025 will decrease by \$9,336 (1%) for a total requisition of \$892,27. This plan does not include the potential replacement of fire halls.

PURPOSE

To present the 2025 - 2029 Financial Plan for the Service to the SVFD Board of Trustees for endorsement.

BACKGROUND

Metro Vancouver’s annual budget process includes the development of detailed annual budgets and the updating of five year financial plans for each of the four Metro Vancouver legal entities (Metro Vancouver Regional District, Metro Vancouver Housing Corporation, Greater Vancouver Water District and Greater Vancouver Sewerage and Drainage District) and related functions.

This report focuses on the Service and presents the 2025 provisional annual budget and the updated five-year plan for the years 2025 to 2029 for SVFD Board of Trustees and Metro Vancouver Board of Directors consideration.

SASAMAT FIRE PROTECTION SERVICE

The Service is a Metro Vancouver Regional District (MVRD) function that includes the Villages of Anmore and Belcarra. The Service has two fire halls, five fire trucks, a pickup truck, a utility terrain vehicle and two trailers. The Service is staffed by approximately 40 trained volunteers including a Fire Chief.

The Service initiatives planned over the next five years are guided by direction provided in the Board Strategic Plan, specifically:

- Continue to engage with members on processes and initiatives that contribute to an effective and well-functioning organization
- Build resilience in communities to prepare for and adapt to changing physical and environmental conditions
- Develop and implement financial plans and policies that reflect a commitment to sound financial management and long-term planning, in consideration of current and future ratepayers
- Enhance relationships between Metro Vancouver and other orders of government, First Nations, adjacent regional districts, and key stakeholders.

2025 BUDGET AND 2025 - 2029 FINANCIAL PLAN

The five-year financial plans for this cycle have been updated to address five central themes identified by the Metro Vancouver Board in its Strategic Plan to guide the development of plans and budgets. The five themes are as follows:

- Financial Sustainability
- Environmental Sustainability
- System Stewardship
- Regulatory and Legislative Environment
- Regional Growth

Each Metro Vancouver function has an Annual Work Plan that includes strategic directions, performance indicators and key actions to guide the work for the coming year.

The *DRAFT* 2025 - 2029 Sasamat Fire Protection Service Financial Plan is included as Attachment 1. The 2025 Annual Work Plan for Sasamat Fire Protection Service is presented in this report and is included in Attachment 2.

Operating Budget Highlights

The Service operating budget is proposed to decrease by \$14,336 in 2025 for a total budget of \$897,271. This decrease can be attributed primarily to a decrease in contribution to the Capital Reserve fund in 2025.

The 2025 operating budget anticipates the following key actions:

- Ongoing fire protection service to the two Villages.
- Continue to provide safety training such as respiratory fit testing and audiometric testing. Review and update Operational Guidelines.

Reserve Funds

The 2025 - 2029 Projected Reserves for Sasamat Fire Protection Service is included in Attachment 3.

Of note in Attachment 3 is the contribution level to the Capital Facility Reserve. For 2022, the contribution increased by sixty percent (60%) to \$167,400 and it increased a further thirty percent (30%) in 2023 to \$348,192 and remained the same in 2024. The contribution level is budgeted to not change in 2025.

APPROVAL PROCESS

The proposed 2025 - 2029 Financial Plan and Annual Work Plan is presented for information before being forwarded to the Board for consideration.

The next steps of the process are:

- The 2025 - 2029 Financial Plan and Annual Work Plan will be presented for consideration to the Finance Committee on October 9, 2024 and at the Board Financial Workshop on November 1, 2024.
- The Board will consider adoption of the 2025 Budget and endorsement of the 2025 - 2029 Financial Plan on November 1, 2024.

ALTERNATIVES

1. That the Sasamat Volunteer Fire Department Board of Trustees endorse the 2025 - 2029 Financial Plan for Sasamat Fire Protection Service as presented in the report “2025 - 2029 Financial Plan – Sasamat Fire Protection Service” dated September 3, 2024 and forward it to the Finance Committee on October 9, 2024 for consideration.
2. That the Sasamat Volunteer Fire Department Board of Trustees make recommendations and endorse an amended 2025 - 2029 Financial Plan for Sasamat Fire Protection Service and forward the amended 2025 - 2029 Financial Plan to the Finance Committee on October 9, 2024 for consideration.

FINANCIAL IMPLICATIONS

If the MVRD Board endorses the 2025 - 2029 Financial Plan for the Service, as presented under Alternative 1, in 2025, the Sasamat Fire Protection Service requisition in 2025 will decrease by \$9,336 (1%) for a total requisition of \$892,271.

Over the term of the five-year plan, the annual Service requisition is projected to increase by an average of \$7,533 per year (0.8%) to provide the required revenue to offset projected expenditures.

Under Alternative 2, the Board of Trustees may wish to consider recommending amendments to the five-year financial plan for consideration at the Board Budget Workshop. Any changes to the plan may have an impact on the MVRD Financial Plan.

CONCLUSION

The 2025 - 2029 Financial Plan for the Service has been prepared to respond to direction provided in the *Board Strategic Plan*. It is presented to SVFD Board of Trustees and Board members to provide overview information on activities and financial impacts for the years 2025 to 2029 for the Service.

The presentation of this year’s five-year financial plan for the Service provides the opportunity for Metro Vancouver to share with its member jurisdictions the proposed Service initiatives over the next five years. It is intended to be used as a guiding document for member jurisdictions in the development of municipal five-year financial plans and includes projections on household impact to demonstrate how the plan will remain affordable for Metro Vancouver residents while keeping pace with our critical requirements.

Staff recommend endorsing the 2025 - 2029 Financial Plan for the Service as presented under Alternative 1.

Attachments

1. *DRAFT* 2025 - 2029 Sasamat Fire Protection Service Financial Plan
2. 2025 Annual Work Plan for Sasamat Fire Protection Service
3. 2025 - 2029 Projected Reserves for Sasamat Fire Protection Service

**METRO VANCOUVER REGIONAL DISTRICT
SASAMAT FIRE PROTECTION SERVICE
2025 - 2029 FINANCIAL PLAN
2025 BUDGET REVIEW**

	2024 BUDGET	2025 BUDGET	% CHANGE	2026 FORECAST	% CHANGE	2027 FORECAST	% CHANGE	2028 FORECAST	% CHANGE	2029 FORECAST	% CHANGE
REVENUES											
Metro Vancouver Regional District Requisitions	\$ 901,607	\$ 892,271	(1.0%)	\$ 899,513	0.8%	\$ 906,945	0.8%	\$ 914,573	0.8%	\$ 922,406	0.9%
Other External Revenues	10,000	5,000		5,000		5,000		5,000		5,000	
TOTAL REVENUES	\$ 911,607	\$ 897,271	(1.6%)	\$ 904,513	0.8%	\$ 911,945	0.8%	\$ 919,573	0.8%	\$ 927,406	0.9%
EXPENDITURES											
Operating Programs:											
Sasamat Fire Protection Service	\$ 416,195	\$ 415,435		\$ 422,019		\$ 428,775		\$ 435,710		\$ 442,831	
Apparatus Acquisitions	-	-		-		-		-		-	
Contribution to Capital Reserve	107,100	92,100		92,100		92,100		92,100		92,100	
Contribution to Capital Facilities Reserve	348,192	348,192		348,192		348,192		348,192		348,192	
	871,487	855,727	(1.8%)	862,311	0.8%	869,067	0.8%	876,002	0.8%	883,123	0.8%
Allocation of Centralized Support Costs	40,120	41,544	3.5%	42,202	1.6%	42,878	1.6%	43,571	1.6%	44,283	1.6%
TOTAL EXPENDITURES	\$ 911,607	\$ 897,271	(1.6%)	\$ 904,513	0.8%	\$ 911,945	0.8%	\$ 919,573	0.8%	\$ 927,406	0.9%

SASAMAT FIRE PROTECTION SERVICE

Description of Services

Sasamat Fire Protection Service is a Metro Vancouver Regional District (MVRD) function established to provide fire protection service to the Villages of Anmore and Belcarra. The service has two fire halls and six trucks staffed by approximately 40 trained volunteers. In 2023, Sasamat Fire Protection Service responded to approximately 134 calls for service with this volume expected to increase as development continues in the service area.

Strategic Directions and High Level Goals Supported

The MVRD Board supports the function of fire protection with respect to Anmore and Belcarra, as conferred by authority provided through Supplementary *Letters Patent*.

Daily fire operations and long term planning for the fire service is the responsibility of a Board of Trustees which is comprised of members from both Villages and one member assigned by the MVRD Board.

MVRD supports the fire service with providing administration services.

2025 Sasamat Volunteer Fire Department Board of Trustees Key Actions

- Commence review of requirements and preparation of job description for possible full-time Fire Chief in 2025.
- Work with Anmore and Belcarra villages regarding new capital facilities.
- Continue to provide safety training such as respiratory fit testing and audiometric testing.
- Review and update Operational Guidelines.

METRO VANCOUVER DISTRICTS
2025 - 2029 PROJECTED RESERVES - SASAMAT FIRE PROTECTION SERVICE

OPERATING RESERVES

	2024 ENDING BALANCE	2025 OPENING BALANCE	CONTRIBUTION	WITHDRAWALS	INTEREST	2025 ENDING BALANCE	2026 ENDING BALANCE	2027 ENDING BALANCE	2028 ENDING BALANCE	2029 ENDING BALANCE
Sasamat Fire Protection Service	\$ 216,379	\$ 216,379	\$ -	\$ -	\$ 5,409	\$ 221,788	\$ 227,333	\$ 233,016	\$ 238,841	\$ 244,812

STATUTORY RESERVES

	2024 ENDING BALANCE	2025 OPENING BALANCE	CONTRIBUTION	WITHDRAWALS	INTEREST	2025 ENDING BALANCE	2026 ENDING BALANCE	2027 ENDING BALANCE	2028 ENDING BALANCE	2029 ENDING BALANCE
Sasamat Fire Protection Service (SFPS)										
SFPS Capital Reserve Fund	\$ 759,725	\$ 759,725	\$ 87,100	\$ -	\$ 20,082	\$ 866,907	\$ 976,768	\$ 1,089,376	\$ 1,204,799	\$ 1,323,108
SFPS Communications Capital Reserve Fund	74,398	74,398	-	-	1,860	76,258	78,164	80,118	82,121	84,174
SFPS Emergency Equipment Reserve Fund	46,965	46,965	5,000	-	1,237	53,202	59,595	66,147	72,863	79,747
SFPS Capital Facility Reserve	1,168,200	1,168,200	348,192	-	33,557	1,549,949	1,941,242	2,342,317	2,753,419	3,174,799
Total	\$ 2,049,288	\$ 2,049,288	\$ 440,292	\$ -	\$ 56,736	\$ 2,546,316	\$ 3,055,769	\$ 3,577,958	\$ 4,113,202	\$ 4,661,828

To: Sasamat Volunteer Fire Department (SVFD) Board of Trustees

From: Brant Arnold-Smith, Program Manager, Protective Services and Emergency Management Metro Vancouver

Date: September 3, 2024 Meeting Date: September 5, 2024

Subject: **2024 SVFD Quarterly Work Plan Update**

RECOMMENDATION

That the SVFD Board of Trustees receive for information the update to the Quarterly Work Plan as presented in the report dated September 3, 2024, titled “2024 SVFD Quarterly Work Plan Update”.

EXECUTIVE SUMMARY

The quarterly work plan presented in this report conveys the priorities for the Sasamat Volunteer Fire Department in 2024 and aligns with the 2024 Business Plans and Budget for the Metro Vancouver Sasamat Fire Protection Service function, approved by the Metro Vancouver Regional District (MVRD) Board.

PURPOSE

To provide the SVFD Board of Trustees an update on the priorities and the quarterly work plan for the SVFD for the year 2024.

BACKGROUND

At its September 6, 2023 meeting, the SVFD Board of Trustees endorsed the 2024 Budget and Annual Work Plans for the SVFD, which served as the basis of the 2024 Budget approved by the MVRD Board on October 27, 2023. The 2024 Annual Work Plans included a list of key actions that have been used to develop the SVFD’s quarterly work plan presented in this report.

2024 WORK PLAN

Attached to this report is the 2024 Quarterly Work Plan Update. The SVFD Board of Trustees is the committee that provides advice and recommendations on policies, bylaws, plans, programs, budgets and issues related to the Sasamat Fire Protection Service.

Key actions in the 2024 work plan for the SVFD Board of Trustees are described below:

- Reviewing and endorsing the annual budget and five-year financial plan for the Fire Protection Service;
- Work with Anmore and Belcarra villages regarding new capital facilities;
- Guiding policy and strategic direction on the performance, operations, and management of SVFD service and assets;
- Guide and support the procurement of a new Firefighting apparatus.

The 2024 Quarterly Work Plan for the Fire Protection Service is attached, including the expected time frame for reports to this Committee. The Committee will be updated on the status of the actions and projects in this work plan per the Committee's schedule.

ALTERNATIVES

1. That the SVFD Board of Trustees receive for information the 2024 Quarterly Work Plan Update as presented in the report dated September 3, 2024 titled "2024 SVFD Quarterly Work Plan Update".

2. That the SVFD Board of Trustees receive for information the 2024 Quarterly Work Plan Update as presented in the report dated September 3, 2024 titled "2024 SVFD Quarterly Work Plan Update" with amendments provided at the September 5, 2024, SVFD Board of Trustees meeting.

FINANCIAL IMPLICATIONS

The priorities in the 2024 Quarterly Work Plan of the Sasamat Volunteer Fire Department are consistent with the 2024 Budget approved by the MVRD Board on October 27, 2023 and with key actions included in the 2024 Annual Work Plans.

CONCLUSION

The 2024 Quarterly Work Plan Update conveys the priorities for the Sasamat Volunteer Fire Department in 2024 and is consistent with its function and the 2024 Budget approved by the MVRD Board. Staff recommend that Alternative 1 be approved.

Attachment

1. Sasamat Volunteer Fire Department 2024 Quarterly Work Plan Update dated September 3, 2024.

2024 Sasamat Volunteer Fire Department Work Plan

Report Date: August 3, 2024

Priorities

1st Quarter	Status
Firefighter Training (monthly)	ongoing
Planning with the two new Deputy Chiefs	ongoing
Firefighter Safety Fit Testing and Audiometric Testing	pending
Fleet Maintenance - CVIPs	ongoing
Live Fire moved from December	postponed
BC Volunteer Fire Chief's Summit in Kamloops	pending
New Recruit Orientation presentation	completed
Firefighter Safety Fit Testing and Audiometric Testing	pending
Work on Tender 2 replacement for 2025	ongoing
Decision and action regarding disposal of Engine 3	pending
2nd Quarter	
Firefighter Training (monthly)	ongoing
Fleet Maintenance	ongoing
Firefighter Safety Fit Testing and Audiometric Testing	ongoing
Produce 2024 SVFD Budget	ongoing
Update SVFD 5 Year Financial Plan	ongoing
Yearly meeting with Port Moody Fire Department, Metro Parks, BC Hydro, RCMP, BC Parks for Wild Fire action plan	Complete
Fire Chief's conference	Did not attend
MV Wildfire conference	Did not attend
Review Fire Inspections and action	Complete
Transfer data from lam Responding – mothball lam Responding	ongoing
Work on Tender 2 replacement for 2025	ongoing
Decision and action regarding disposal of Engine 3	ongoing
3rd Quarter	
Firefighter Training (monthly)	ongoing
Ground Ladder testing	scheduled
Annual OG review	ongoing
Live Fire Training Prep	ongoing
Review and update Operational Guidelines Same as Annual OG review	updating
Approve 2024 SVFD Budget and 5 Year Work Plan	ongoing
Work on Tender 2 replacement for 2025	suspended
4th Quarter	

Firefighter Training (monthly)	ongoing
Firefighter Safety Fit Testing and Audiometric Testing	pending
Live Fire (Firefighter Training)	pending
Equipment review - purchases	pending
Work on Tender 2 replacement for 2025	pending

SASAMAT VOLUNTEER FIRE DEPARTMENT

3.5

FIRE CHIEF'S REPORT

September 5, 2024

MANPOWER:

Fire Station	Officers	Regular Members	Recruits In Training	Field Incident Techs	Extended Leave	Net Responders
Anmore Hall	5	11	4	2	4	22 + 4
Belcarra Hall	5	5	1	2	0	13 + 0
Totals	10	16	5	4	4	35 + 4
<i>Targets</i>	<i>1 per 5 (9)</i>	<i>31 Members</i>		<i>5 Members</i>	<i>0</i>	<i>45 + 0</i>

APPARATUS:

GVRD #	Vehicle Description:	Status / Summary:
1-3120	2003 Freightliner Rescue 5	Regular PMP from Metro Fleet
1-3112	1995 GMC TopKick Tender 2	Regular PMP from Metro Fleet
1-8015	1998 Spartan/Smeal Ladder 7	Limited Service
1-8011	2017 Spartan Engine 1	Regular PMP from Metro Fleet
1-3121	2006 Kubota ATV ATV #1	Regular PMP from Metro Fleet
A-2001	2011 Ford F150 Sierra 8	Regular PMP from Metro Fleet
A-4000	2023 International New Engine 3	New in service

2.0 EQUIPMENT:

- 2.1 No major truck issues since the last meeting.
- 2.2 We are continuing to train on new Engine 3. This vehicle is now in full service, and members continue to get signed off on driving it.
- 2.3 Further work on Tender 2 replacement has been put on hold pending Trustee direction.
- 2.4 Old Engine 3 has been sold to the Hawkins Lake Volunteer Fire Department for \$6500.00. We had it at auction for several weeks with no bids.

3.0 HALLS AND GROUNDS:

- 3.1 Maintained by Municipal Staff, Cleaned by Contract Cleaners.

- 3.2 The grass cutting at Anmore Hall has been limited to the lawn area only. When Village staff are there, they do not do any other work such as line trimming overgrown areas.
- 3.3 The tarmac at the Anmore Hall in front of the rescue bay has been replaced. It was determined that there is a large volume of ground water in that area that could cause problems again.

4.0 TRAINING:

- 4.1 Training is ongoing.
- 4.2 The current Recruit group is nearly fully trained. Some have been to some wildland fires as they are fully trained for that.
- 4.3 Training for this year has included some of the following:
 - Ladders
 - Auto Extrication
 - Water Supplies
 - Ropes and Knots
 - Radio Communications
 - WIFF Training
 - FR Medical training
 - Incident Command
 - Fire attack
- 4.4 We are looking to send two additional members to become certified FR Instructors.

5.0 PUBLIC EDUCATION:

- 5.1 Firefighter Miranda Venos has completed six fire hall tours with various school groups.

6.0 OLD BUSINESS / UPDATES:

- 6.1 The antenna at the Anmore Fire Hall has now been replaced with a noticeable improvement in radio reception.

7.0 REPORTS AND INFORMATION:

- 7.1 Duty Roster (Attached)

7.2

Total Call-outs for 2024 year to date as of February 20, 2024

9	FIRES, structural, ground, vehicle & hydro
50	MESA
3	MVI
3	Other
22	Alarms
87	Total calls YTD

8.0 NEW BUSINESS:

8.1 DC Richardson is currently conducting a review of the stipends paid to the Volunteers. The aim of this is to see if an increase is warranted and if it would help with recruitment and retention.

9.0 CORRESPONDENCE:

9.1 None.

RESPECTFULLY SUBMITTED:

A handwritten signature in black ink, appearing to read "Jay Sharpe". The signature is written in a cursive style with a long horizontal stroke at the end.

Jay Sharpe, Fire Chief

SASAMAT VOLUNTEER FIRE DEPARTMENT

TO: SASAMAT BOARD OF FIRE TRUSTEES
FROM: Jay Sharpe, Fire Chief
DATE: September 5, 2024
RE: 7.1 Duty Rosters

PURPOSE:

On a regular basis Operating Guideline #5.01.20 and the individuals whose names appear therein, will be submitted to the Sasamat Board of Fire Trustees as part of the Fire Chiefs Report.

RECOMMENDATION:

That Duty Roster Operating Guideline #5.01.20 as amended is received.

OPERATIONAL GUIDELINE

SASAMAT VOLUNTEER FIRE DEPARTMENT	O.G. #5.01.20
TITLE: SVFD DUTY ROSTER (45 FF + 5 AM max)	Page 2 of 2

REGULAR MEMBERS:

Jay Sharpe	Fire Chief
Colin Richardson	Deputy Chief, Administration
Mike Bolam	Deputy Chief, Operations
Robert Schofield	Captain
Jason Sadler	Captain
Jol Drake	Captain
Britt Andersen	Lieutenant
Adon Albanese	Lieutenant
Keiran Lancaster	Lieutenant
Nigel Terrett	Lieutenant
Bill Cooke	Fire Fighter
Bradley Smith	Fire Fighter
Ken Honigman	Fire Fighter
William Crocker	Fire Fighter
Miranda Venos	Fire Fighter
Sarah Coombes	Fire Fighter
Greg Wright	Fire Fighter
Brad Taverna	Fire Fighter
Isaac Heisler	Fire Fighter
Brielle Rheaume	Fire Fighter
Don Babineau	Fire Fighter
Steven Chislom	Fire Fighter
Allan Stevenson	Fire Fighter
Will Muxworthy	Fire Fighter
Sophie Gable	Fire Fighter
Clare Heisler	Fire Fighter

Field Incident Technicians (FITs)

Greg Winterbottom	FIT
Al Harmer	FIT
Doug Brain	FIT

Owen Wood

FIT

Probationary Fire Fighters:

Sonny Mann
Brienne Leonard

Probationary
Probationary

Recruits in Training:

Daniel Sutton
Josh Hansma
Richard Friedland
Katherine Golbey
Ian Marchese

Recruit
Recruit
Recruit
Recruit
Recruit

Work Experience Student

None at this time

On Leave

Trevor Mueckel
Reverend David Anderson
Derek Schmidt
Joe Nicholas
Alex Hazlett

FIT, Equipment Officer
Asst. Chief SVFD Chaplin
Fire Fighter
Fire Fighter
Probationary

ASSOCIATE MEMBERS:

Keith Evans
Paul Kallio
Larry Scott
Judy Evans
Jamie Roberts

Associate
Associate
Associate
Associate
Associate

*Note - Those names appearing with an asterisk * are on leave from active duty but are still considered Members, Probationary Members, Recruits in Training or Associate Members.*

Signature of Fire Chief _____	This O.G. Replaces: _____
Date of Issue: _____	Issued on: _____

RESPECTFULLY SUBMITTED:



Jay Sharpe, Fire Chief