

# BLOCK WATCH

Participant Manual



**FOR SAFER  
COMMUNITIES**

Block Watch and the accompanying logo are the registered trade marks of the Block Watch Society of B.C.

# BLOCK WATCH

## CONTENTS:

**BLOCK WATCH IS A PROGRAM OF 'NEIGHBOUR HELPING NEIGHBOUR'. THE PROGRAM IS A FREE, COMMUNITY BASED CRIME PREVENTION PROGRAM ADMINISTERED BY YOUR LOCAL POLICE. RESIDENTS ON A STREET, (TOWN HOMES, MOBILE HOMES, APARTMENT BUILDINGS ETC.) FORM A COMMUNICATION CHAIN. THEY ARE COMMITTED TO WATCHING OUT FOR EACH OTHER AND REPORTING ALL SUSPICIOUS ACTIVITY.**

<b>PROGRAM OPERATION -----</b>	<b>2</b>
<b>HOME SECURITY AND PROPERTY IDENTIFICATION -----</b>	<b>5</b>
<b>HOW MUCH WOULD YOU LOSE? - AN INVENTORY OF YOUR HOME-----</b>	<b>7</b>
<b>SUSPECT IDENTIFICATION FORM-----</b>	<b>10</b>

# BLOCK WATCH...

## SAFER COMMUNITIES

### THE PROCEDURE



The success of the Block Watch Program relies on the prompt reporting of all suspicious activity. Many Neighbourhood crimes have been prevented because alert neighbours have made a call to the police.

#### ① CALL POLICE



#### ② CALL BLOCK CAPTAIN

He or she will then alert:

1. Assigned Neighbours
2. Assigned Area Coordinator

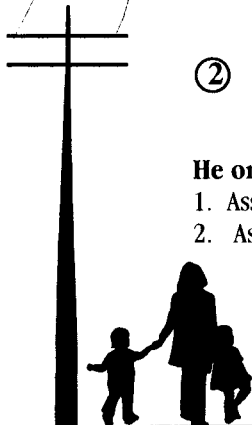

The Block Watch Program is not a new concept. It was introduced in Seattle in 1973, and since then it continues to combat local crime in communities throughout the modern world.

The concept is simple... neighbourly concern.

Block Watch is a volunteer program consisting of a Block Watch Captain, a Block Watch coordinator and your local Police.

This booklet was prepared to assist citizens interested in organizing a local Block Watch Program. The Program was created in an effort to decrease residential break-ins through organized neighbourhood participation.

This program is successfully operating in many North American communities, and because it functions with the **organized** involvement and cooperation of community members, it is a proven crime deterrent. Community members are the key factor to safer communities.

### THE TEAM

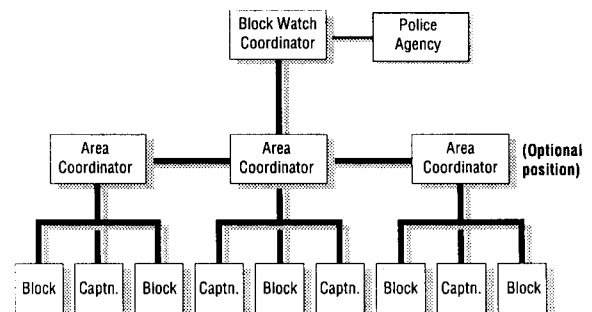

### THE COMMUNITY

Examples of suspicious activity that should be reported:

1. Slow moving vehicles ..... possible burglars casing homes
2. Unknown vehicle loading valuables ..... possible break-in in progress
3. Property carried by persons on foot ..... possible stolen property
4. Persons going door to door ..... possible burglars casing homes
5. Stranger in back yard ..... possible burglar looking for an entry point
6. Door/window forced open ..... possible break-in in progress



# BLOCK WATCH...

## PROGRAM DYNAMICS

### THE BLOCK WATCH MEETING

A neighbourhood meeting is the first step in creating a Block Watch community. Your Block Watch Captain will introduce you to your neighbours and the Block Watch team.

### THE BLOCK WATCH MAP

The neighbourhood map is important to the Block Watch Program members because it identifies all the homes in your block, with contact names and phone numbers for cases of emergency.

### REPORTING A CRIME

The Police will need all the details that you can give them. Write down the person's sex, approximate age and height, the colour of clothing such as jacket, shirt, pants and shoes. Keep your original notes and give a copy to police.

In the case of suspicious vehicles, look for the licence number, the colour, body style (e.g. two or four door sedan), and any unusual characteristics such as a loud muffler, wide tires, rust or missing parts and bumper stickers.

**PLEASE REFER TO FORM ON INSIDE BACK COVER.**

BLOCK WATCH MAP	
BLOCK NO: <u>1</u>	
Police Emergency Phone: _____	
Police Non-emergency phone: _____	
Block Captain: <u>S. Barry</u>	
Co-captain: <u>R. Inglis</u>	
Date: <u>Aug. 23, 1998</u>	
	
412 RED INGLIS 555-1111 CO-CAPTAIN	411 SAM & MARY SMITH 555-1132
410 CAL & DI YOUNG 555-1131	409 BILL JONES 555-1235
408 QUAN & HO LEE 555-1151	407 RON JENKIN 555-1158
406 BASHIR BARRY 555-1177 BLOCK CAPTAIN	405 SAM BOURN 555-9177
404 HELEN REEVE 555-1190	403 JOHN J. RANKIN 555-1234
402 GEORGE CHEEKS 555-1132	401 ROB CLOWDER 555-1875
400 JOE PITRE 555-1135	399 DON PLUM 555-9753
398 SAL ROSIE STONE 555-1177	397 JAKE JASPER 555-8743

### MAKE THE CALL COUNT

- STAY CALM
  - STAY ON THE PHONE
- UNTIL YOU ARE TOLD TO HANG UP
- LET THE OPERATOR CONTROL THE CONVERSATION
  - GIVE ALL THE INFORMATION REQUESTED
- You will be asked for some personal details, including a birthdate. This information is used in the police files.

### HOW CALLS ARE HANDLED

All calls are handled on a priority level and divided into two basic categories.

#### EMERGENCY CALLS [9][1][1]:

These include crimes in progress, such as break-ins, vandalism, and situations when the suspect is still present. The police are dispatched on a high priority to these calls.

***Some communities may not have a 911 service. Check your phone book for the correct emergency numbers.***

#### NON EMERGENCY CALLS:

These are situations in which the crimes have already been committed and no suspects are present. The police are dispatched to deal with these calls on availability of manpower.

Always obtain a file number for reference purposes. You must tell the operator when calling if you want police attendance at your home.



# BLOCK WATCH...

## PROPERTY IDENTIFICATION - HOME SECURITY

### PROPERTY IDENTIFICATION

Burglars seldom steal things for their own personal use. They steal items that are portable, easily converted to cash, and most particularly, items that cannot be identified as to ownership.

Property identification will discourage a burglar from breaking into your home if all personal property is identified, as this creates a high risk for the thief. Here's how it works:

Police agencies have immediate national and international communications via computer. Within seconds, this system can give a status report on any properly identified item. Proper identification is essential however, and that is where you can work together with your police.

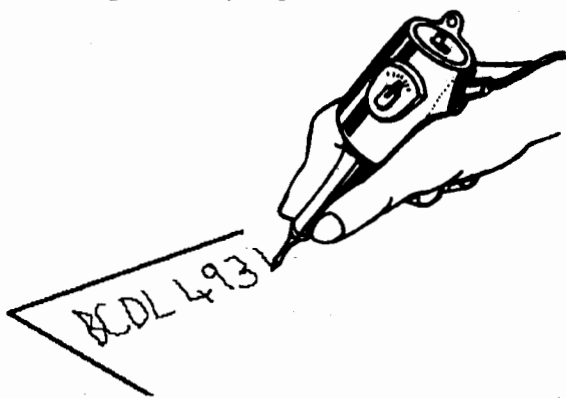

1. Obtain an engraving pen for your block/neighbourhood, and let the Block Captain keep track of it. You may also want to purchase your own engraver.
2. Engrave all your valuables with your B.C. drivers licence number in TWO places
3. Photograph or video tape items you do not want to mark, such as jewellery, art and delicate glass. Make a ruler (as the example shown) to visually determine comparative size.

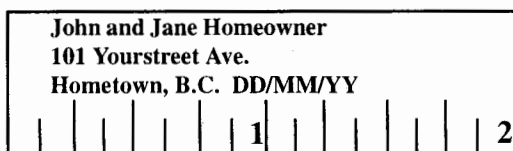

4. Use the Property Inventory provided (*see pages 9 and 10*) to help record all your items.
5. After all items are marked, obtain Block Watch stickers from your Block Captain.

### HOME SECURITY

Most burglars look for opportunities – points of easy entry – to get into your home. They take whatever they want and leave.

The facts are that an overwhelming number of break-ins are executed with little or no force, AND can be prevented.

The best way to prevent a burglary is to eliminate the opportunities. By making your home more secure, burglars can't gain entry without spending excessive time and creating more noise than they are willing to risk.

#### OUTSIDE YOUR HOME

Home security starts where the burglar starts – on the OUTSIDE. Most burglars are adept at seeking external 'weak spots' which more often than not, reflect the overall quality of your home's security.

#### Shrubbery



When offering concealment near entries or windows, shrubbery should be trimmed to eliminate any hiding places. Basement windows are a common point of entry and are often hidden by shrubbery. These windows should be replaced with unbreakable lexan or plexiglass, or install decorative security bars.

#### Lighting

Front and back porch lights should be kept on from dusk to dawn as well lit areas deter burglars.. High or caged lighting is preferable.

#### Tools and Ladders

Keep all tools and ladders securely locked and out of sight. Burglars may use these tools to break into your, or a neighbour's home.

#### House Numbers

Be sure your house number is clearly visible from the street, especially if you have a long driveway. Be sure it can be seen at night and that no plants grow over it.

Emergency vehicles will be able to identify your home easily and quickly in the event of an emergency.

#### Lane Access

Ensure that this area is both well-lit and secure. House numbers should also be easily visible from your lane.

# BLOCK WATCH...

## HOME SECURITY TIPS (DOORS AND LOCKS)

### EXTERIOR DOORS:

On most homes, an exterior door is easy to get into because the door frame is inadequately secured and/or the wood which makes up the frame is weakened due to weather, age, etc. When a door is kicked, the frame usually gives way, allowing the burglar to enter.

Check the condition of wood frame. If worn, have a new frame made. Anchor the frame into the wall studs. Do this by removing short screws used to secure the strike plate and hinge plates. Replace them with 3" - 4" screws; this should be done to all exterior doors.

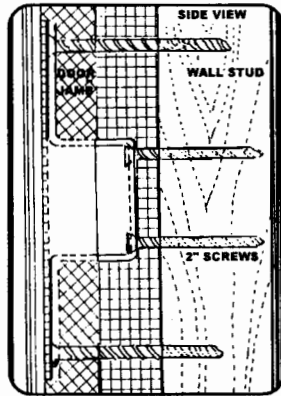

In terms of vulnerability, the following three doors pose the greatest concern because they allow easy access to locks and knobs.

#### Hollow Core Doors

Comprised of a wooden frame with two thin sheets of plywood glued to either side and usually filled with corrugated cardboard. Access is gained by punching or cutting a hole through the door.

#### Panel Doors

Basically solid in the main construction. However, some panels are thin and easily punched or kicked in.

#### Doors with Upper Glass Panels

Upper half contains a thin pane of glass which can easily be broken.

#### SOLUTIONS:

1. Reinforce existing doors. You can do this by measuring the outside dimension of the door. Allow for knobs, locks etc. Purchase a 1/2" thick sheet of marine grade plywood and attach to the outside of door with glue or screws.
2. Replace the glass pane. Install a durable plastic product or treated glass. (Refer to the section on Alternatives to Glass).
3. Replace ALL exterior doors with solid core doors. Solid lumber or steel is recommended. Be advised that some 'solid core' doors are actually constructed of particle board and are not as durable.

#### Peephole

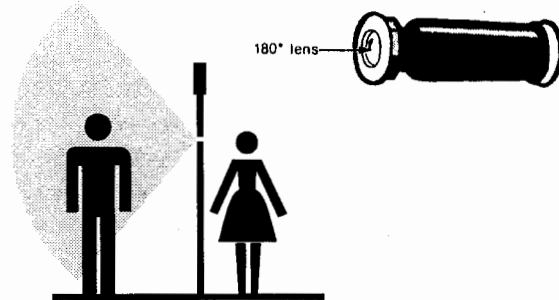

Install a wide angle (180°) peephole in the entrance doors so that visitors can be viewed without opening the door. It should be placed at a height convenient for all family members.

*Peephole viewer allows seeing who is at your door without opening the door.*



#### Night Chains

Do not rely on night chains. They can usually be broken with little effort. Install a wedge-stop as illustrated, ensuring that both your door and the stop are of solid construction.

## LOCKS

### KEY-IN-THE-KNOB LOCKS

This is a very common lock which has a keyed mechanism built into the knob. It is easily defeated by breaking the knob or by wrenching off the knob.

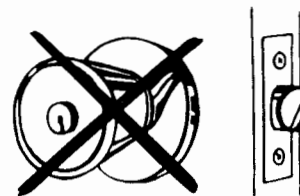

*Key in the knob lock*

**DO NOT USE THIS KIND OF LOCK ON EXTERIOR DOORS.**

# BLOCK WATCH...

## HOME SECURITY TIPS (DOORS AND WINDOWS)

### DEADBOLT LOCKS

All deadbolt locks should come with a 1 1/2-2" throw (see illustrations), and be affixed securely to the door with hardened steel bolts. They are available as:

#### Single Cylinder

Has a thumb turn on the inside and is keyed on the outside. Install on all solid or reinforced doors where access to locks and knobs cannot be gained by breaking adjacent glass.

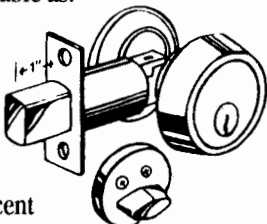

### FIRE MARSHALL'S WARNING:

**DOUBLE CYLINDER LOCKS (KEYED BOTH SIDES) ARE EXTREMELY HAZARDOUS IF THE DOOR THEY SECURE SHOULD EVER NEED TO BE USED AS A FIRE OR EMERGENCY EXIT.**

## SLIDING GLASS

### DOORS AND WINDOWS

Secure the door or window using pins.

First, inspect the point where the inner and outer frames overlap. If you can drill without breaking the glass, drill a downward-angled hole completely through the inner frame and halfway through the outer frame. Insert a sturdy pin or nail snugly into the hole. (be sure that it is long enough to remove and re-insert if necessary). This method will prevent the door or window from sliding.

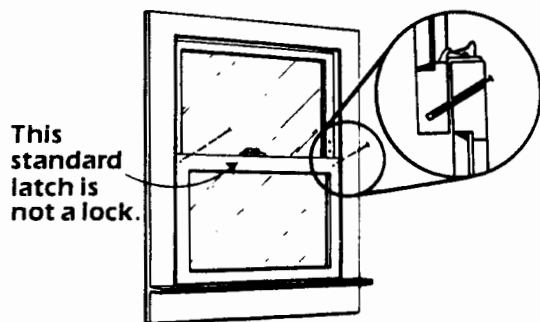

This standard latch is not a lock.

Double-hung windows have two sections with a latch between.

Sliding glass doors and windows are similarly constructed and share common security problems, although windows are by far the weakest link in the security chain. Both often have inadequate locking mechanisms that can be easily forced open.

Determine whether your door or window slides on an:

#### Inside track

install a snug fitting wooden or metal dowel into the bottom track or purchase a "charlie bar".

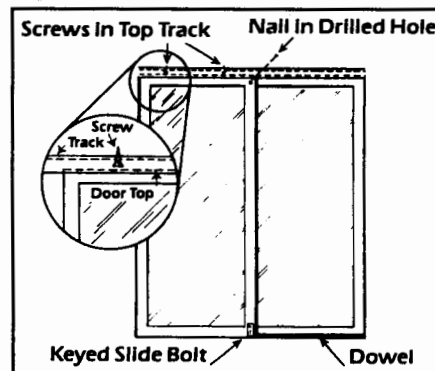

#### Outside track

install a slide bolt along the bottom inside track. Commercial locking devices are also available.

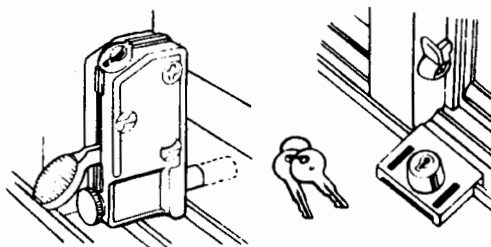

#### Shims

If your sliding door or window can be lifted out of the track, this means there is more vertical space than necessary. To prevent the door from being lifted out, use large head sheet metal screws in the top track at both ends and in the middle. Adjust screws to fill the space and allow the door to freely slide. Commercial shims are also available.

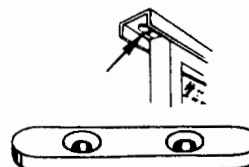

# BLOCK WATCH...

## HOME SECURITY TIPS (WINDOWS AND CHECKLIST)

### WINDOW SECURITY

#### DOUBLE-HUNG WINDOWS

These usually have a top half that can be lowered and a bottom half that can be raised. A latch is situated in the centre where both halves overlap. Burglars gain entry by prying the latch and lifting the window. Or, they break the glass, reach in and undo the latch.

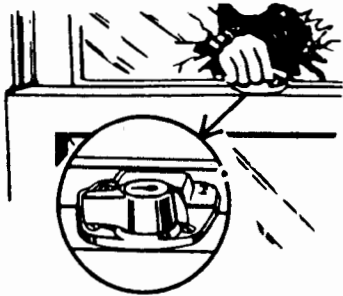

#### CASEMENT WINDOWS

These windows swing open and are hinged at the top, side or bottom.

As with double-hung windows, entry is usually gained by breaking a small piece of glass near the latch and reaching through to undo the latch.

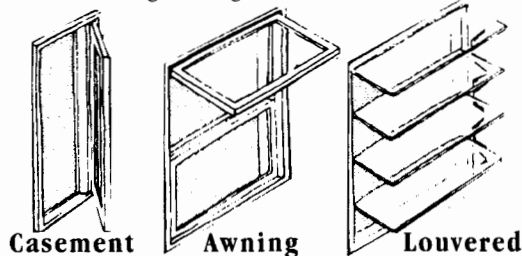

#### SECURITY SOLUTIONS

If the window is not being used as an emergency escape or ventilation, permanently seal the window with nails or screws.

Replace the latch with a keyed latch

Pin the windows with a nail or pin.

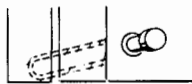

#### GLASS WINDOW ALTERNATIVES

Plastic, treated glass and security film are effective alternatives. Durable security film can also be applied on the existing windows. Consult a glazier for professional advice.

**Security improvements are no guarantee to prevention of burglary. They 'slow the burglar down'. Vigilance and working together as a watchful community will always be the best solution to crime.**

Before you begin to improve your home security, identify entry points most likely to be used by a burglar. Do this by answering the following questions:

- Which entrances are hidden or out of view?
- If locked out of my house, where could I get in without much difficulty?

All those you identify should be secured. Your goal is to make entry more difficult for the burglar by forcing them to take more time and make more noise!

#### DO NOT COMPROMISE FIRE SAFETY FOR SECURITY.

You should have fire escape routes in your home; you and your family should have 'fire drills' to ensure your safety, particularly if you have young children at home.

### A FINAL CHECKLIST

	YES	NO
• Are all your exterior doors strong enough to withstand excessive force?	<input type="checkbox"/>	<input type="checkbox"/>
• Are all exterior doors secured with a deadbolt lock that has a minimum 2 cm. (1") throw?	<input type="checkbox"/>	<input type="checkbox"/>
• Are all strike plates and frames for exterior doors anchored to the home's main framework?	<input type="checkbox"/>	<input type="checkbox"/>
• Do all exterior doors fit snugly and are free of warping, cracks, and other signs of wear?	<input type="checkbox"/>	<input type="checkbox"/>
• Is there a wide-angle peephole/viewer on the main entrances?	<input type="checkbox"/>	<input type="checkbox"/>
• Are sliding glass doors and windows secure against force or being lifted out of the frame?	<input type="checkbox"/>	<input type="checkbox"/>
• Are high-risk windows (hidden, garage, basement etc.) secured sufficiently?	<input type="checkbox"/>	<input type="checkbox"/>
• Are double hung windows secured with pins or extra locks?	<input type="checkbox"/>	<input type="checkbox"/>
• Do all windows have adequate locks in good condition?	<input type="checkbox"/>	<input type="checkbox"/>
• Are trees and shrubs trimmed to allow clear visibility around the perimeter of your home?	<input type="checkbox"/>	<input type="checkbox"/>
• Do you have timers to activate interior/exterior lights in your absence?	<input type="checkbox"/>	<input type="checkbox"/>
• Are all entrances to your home well lighted at night?	<input type="checkbox"/>	<input type="checkbox"/>
• Is your address clearly visible from the street and lane both day and night?	<input type="checkbox"/>	<input type="checkbox"/>
• DO YOU ALWAYS USE YOUR SECURITY DEVICES?	<input type="checkbox"/>	<input type="checkbox"/>





# BLOCK WATCH - How MUCH WOULD YOU LOSE?

A complete household inventory, record of insurance policies and credit cards will be of value to police and insurance adjusters if you suffer a burglary or other loss. Please take the time to conduct an inventory **TODAY!**

LIVING ROOM	
ARTICLE	ESTIMATED VALUE
Chesterfield	
Chair(s)	
Lamp(s)	
Table(s)	
Radio	
HiFi-Stereo	
TV Set	
Rug/Carpet	
Bric-a-brac	
Clock(s)	
Art	
Curtains/Drapes	
Piano and musical instruments	
Other	
<b>TOTAL</b>	<b>\$</b>
DINING ROOM	
Table	
Chairs	
China Cabinet	
Buffet	
Serving Table	
Rug/Carpet	
Curtains/Drapes	
Appliances	
Other	
<b>TOTAL</b>	<b>\$</b>

FAMILY-REC ROOM	
Chairs	
Curtains/Drapes	
Chesterfield	
Tables	
Lamps	
Rug/Carpet	
Desk	
Rug/Carpet	
Bric-a-brac	
Other	
<b>TOTAL</b>	<b>\$</b>
KITCHEN	
Table	
Dinette Set	
Appliances	
Dishes	
Cutlery	
Utensils	
Pots and Pans	
Stove	
Refrigerator	
Other	
<b>TOTAL</b>	<b>\$</b>
BATHROOMS	
<b>TOTAL</b>	<b>\$</b>

VERANDA or PATIO	
Chairs	
Dining Set	
Sofa	
Glider	
Lamps	
Table(s)	
Cooking Equip.	
Other	
<b>TOTAL</b>	<b>\$</b>
BEDROOM No.1	
Chair(s)	
Bed(s)	
Bedding	
Night table	
Dressing Table	
Bench	
Chest of Drawers	
Mirror	
Rug	
Lamps	
Bric-a-brac	
Toilet Articles	
<b>TOTAL</b>	<b>\$</b>

BEDROOM No. 2	
Chair(s)	
Bed(s)	
Bedding	
Night table	
Dressing Table	
Bench	
Chest of Drawers	
Mirror	
Rug	
Lamps	
Toilet Articles	
Clock	
Curtains/Drapes	
Other	
<b>TOTAL</b>	<b>\$</b>
BEDROOM No.3	
Chair(s)	
Bed(s)	
Bedding	
Night table	
Dressing Table	
Bench	
Chest of Drawers	
Mirror	
Rug	
Lamps	
Toilet Articles	
Clock	
Curtains/Drapes	
Other	
<b>TOTAL</b>	<b>\$</b>

VALUABLE PROPERTY		
Item	Make	Model

INSURANCE POLICIES			
Type of insurance	Amount of insurance	Policy No.	Expiry date



# BLOCK WATCH...

## SUSPECT IDENTIFICATION FORM



Keep this form handy to record an accurate record of events should you be witness to a crime in your neighbourhood. Fill in all blanks with a pen and keep this in a safe place until requested by police. It could help apprehend the criminal(s), and will most certainly be useful for police reporting and if required in a court case.

**Be sure you keep the original as copies are inadmissible in court!**

GENERAL APPEARANCE			
SEX: Male <input type="checkbox"/> Female <input type="checkbox"/>		WEIGHT	
AGE		RACE (BLACK, WHITE, ASIAN, OTHER)	
HEIGHT		HAT	
HAIR		COAT	
EYES		SHIRT	
COMPLEXION		PANTS	
JEWELLERY		SHOES	
SCARS		TIE	
TATTOOS and other identifying marks:			

FACE	
Hair style	Skin/hair colour
Hair texture	Shape of eyebrows
Ear size and shape	Wrinkles
Size and shape of eye	Shape of nose
Cheeks (full or sunken)	Moustache or beard
Mouth and lips	Neck and Adams Apple
Write below any specific facial details that you definitely remember:	
What, if anything, did the suspect say?	
Tool or weapon carried by suspect:	
OTHER INFORMATION	
WITNESS NAME:	
WITNESS ADDRESS:	
PHONE #:	
DATE:	TIME:
WEATHER:	

VEHICLE LICENCE NUMBER			
Colour	Make	Model	
Body Style		Damage /Rust	
Antenna	Bumper sticker	Wheel Covers	
Direction of travel (including street and compass heading if known)			

*This manual sponsored by ...*



BRITISH  
COLUMBIA

Ministry of Attorney General